

Gilson BROTHERS COMPANY

BOX 152. PLYMOUTH, WISCONSIN 53073. U.S.A.. PHONE (414) 893-1011

September 18, 1974

Service Bulletin #85

TO: All Unit, Parts Distributors and Parts Dealers

SUBJECT: Gear Drive Snowthrowers Belt, Pulley, Chute Collar Idler Bracket Roll Pin, Wheel and Tire Corrections. Models 55012 - 55012A - 55017

A variety of complaints were received last year in regard to the gear drive snowthrower operation. Some of these were originally covered in Service Bulletin #68 dated December 28, 1972, and the Owner's Manual.

The following corrective action is suggested on units experiencing problems in the field, manufactured prior to 1975 production, only when problems exist.

PROBLEM: Traction belt jumps off pulley or rolls over.

CAUSE: Idler pulley does not hold enough tension onto belt when snowthrower hits solid object like ice, solid frozen snow, or raised portion or uneven sidewalk.

CORRECTION: Install new belt guide stop #32057 to hold belt in pulley when shock load experienced.

1. Drill 5/16" hole in frame 1/2" from inside edge and 3 1/2" back from front edge of idler slot.
2. Engage traction clutch lever.
3. Attach belt guide strap--within 1/16" of belt and pulley--be sure guide is square with belt and belt is engaged. (See Fig. 1.)

PROBLEM: Traction belt chewed up from chain riding belt.

- CAUSE:
1. Cotter pin on chain connecting link incorrectly positioned on belt side--remove cotter pin and connecting link reposition so cotter pin on frame side of chain.
 2. Wheels and klik pins incorrectly positioned in outer axle shaft hole for traction drive. As outlined in Owner's Manual and Service Bulletin #68 dated 12-28-72, wheels should drive in inner hole as outside hole is for free wheeling only.

CORRECTION: Install klik pins through wheel hole and inside hole of axle shaft; then push new retainer ring #32224 onto axle shaft until it is tight against wheel hub. This will prevent wheel from being pulled to outside hole for incorrect position for driving unit and causing premature belt failure. (See Fig. 2)

PROBLEM: Traction and auger belts do not line up close to center of idler.

CAUSE: Idler rod loose or has end play.

CORRECTION: Separate auger housing from drive assembly by removing the four acorn head capscrews. Check that idler rod support brace is at 90° angle to side of housing. Remove 1/8" x 3/4" roll pin holding idler assembly to idler rod. Pull rod back and install up to three 3/8" SAE plated flat washers to the end of the rod to remove slack or end play of the rod. Reinstall roll pin to hold idler to rod. Realign engine pulley to traction or rear drive pulley on transmission shaft. Loosen auger input pulley setscrews. Reassemble auger housing to drive assembly with the four acorn head capscrews. Align impeller input pulley to outer groove of engine pulley with a straight edge and retighten impeller input pulley setscrews. If idler still does not line up close to the center of the idler pulleys then idler bracket is bent or twisted and must be rebent using a pliers or adjustable wrench.

NOTE: Be sure idler rollers contact belt evenly and straight or idler will cause belt to walk off the pulley.

PROBLEM: Traction and impeller--pulley setscrews loosen up.

CAUSE: Setscrews not torqued tight enough or shock loads.

CORRECTION: Tighten setscrews to 140 inch pounds of torque and install a second or locking half dog point setscrew part #31951 in hole located 90° to keyway. A second setscrew can not be installed in keyway setscrew hole due to the thinner portions of the hub for the keyway. (See Fig. 3.)

PROBLEM: Chute hold down collar on auger housing breaks loose.

CAUSE: Collar not welded at position opposite of worm bracket for chute control on auger housing. Excessive pressure caused by chute control worm being adjusted too tight caused the collar to break or become distorted on early 1973 models. Late last year a change in welding procedures included weldment of the collar at the position across from the chute worm bracket.

CORRECTION: Weld collar continuously to auger housing at least two inches past both sides of worm chute bracket and skip weld around remainder of collar. If collar has pieces broken out, remove old collar, grind off weld, install new collar #24285. (See Fig. 4.)

PROBLEM: Idler arm roll pin falls out.

- CAUSE:**
1. Hole in idler arm for rod pin has enlarged broken edge causing loose fit of roll pin.
 2. Defective roll pin.

- CORRECTION:**
1. Install new roll pin.
 2. Insert piece of wire through hole of roll pin and twist wire around shaft so roll pin will not fall out.

Service Bulletin #85

Page 3

PROBLEM: Pneumatic tires lose air pressure.

- CAUSE:
1. Low tire pressure.
 2. Paint runs, rust or weld beads on wheel rim where tire bead seals.

- CORRECTION:
1. Check air pressure--new specification is 20 pounds of pressure. Inflate tire to 40 pounds to seat tire beads, then reduce to 20 pounds.
 2. Remove air from tire, push tire beads away from rim, remove paint runs by sanding or chip weld splatter beads off rim and sand or file smooth.
 3. Use water tank and check for holes in tire or porous side wall of tire.

Service Department

RLM;bjk

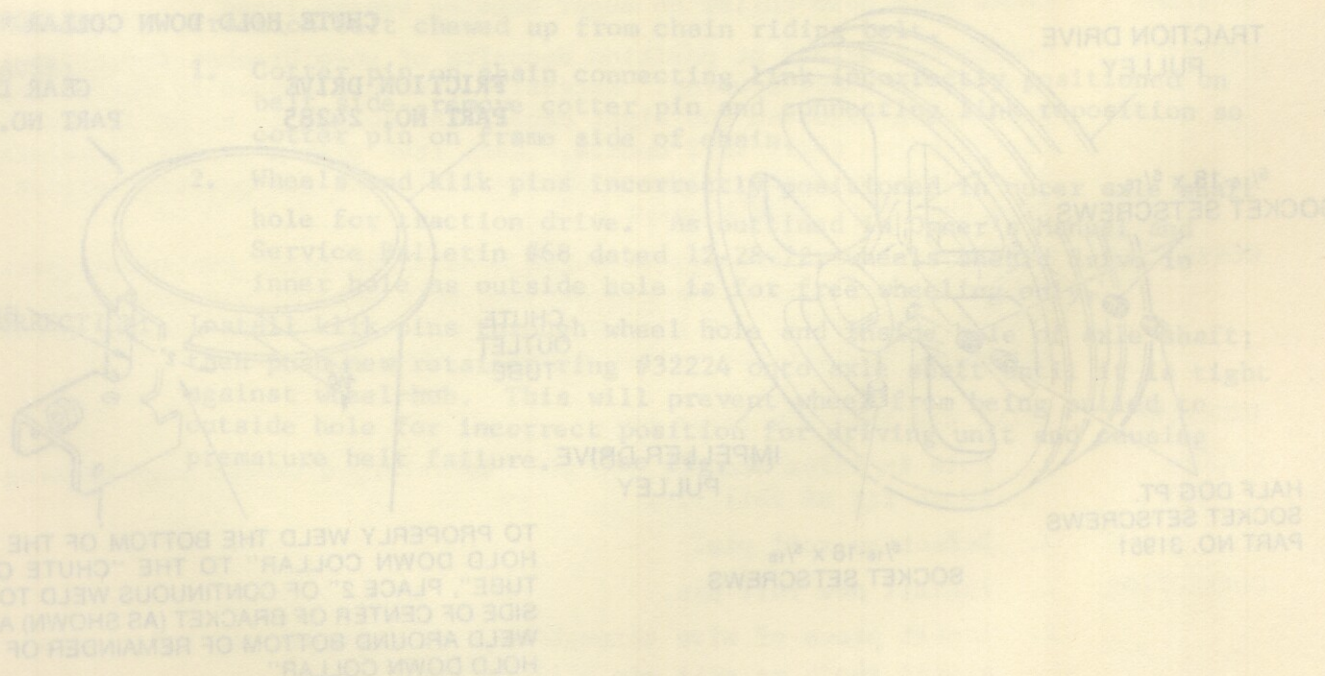

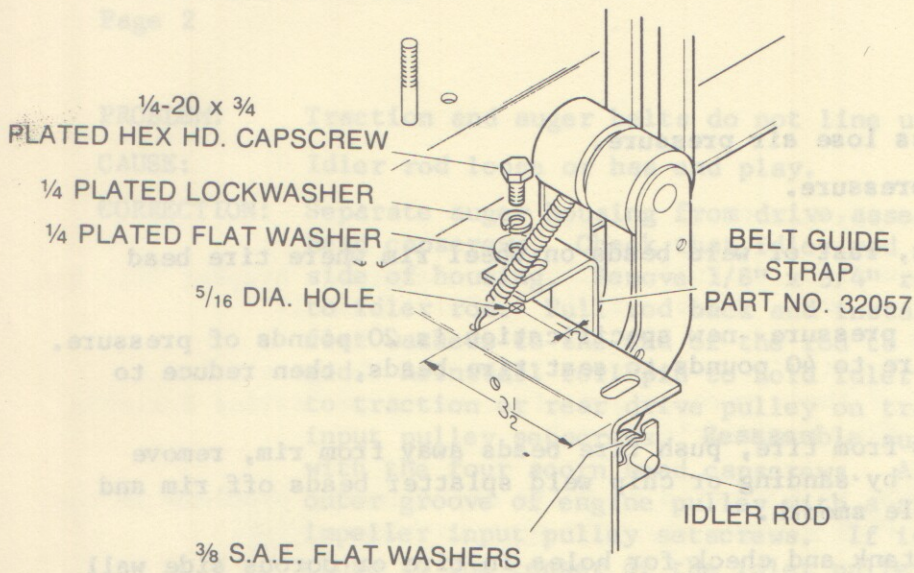

FIG. 1

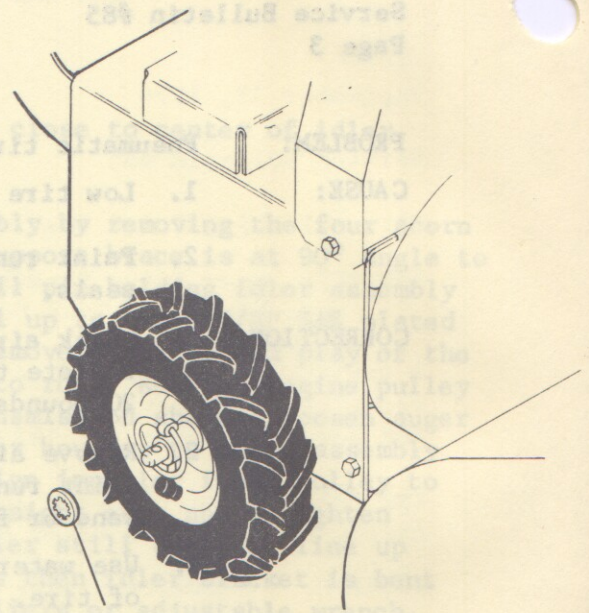

FIG. 2

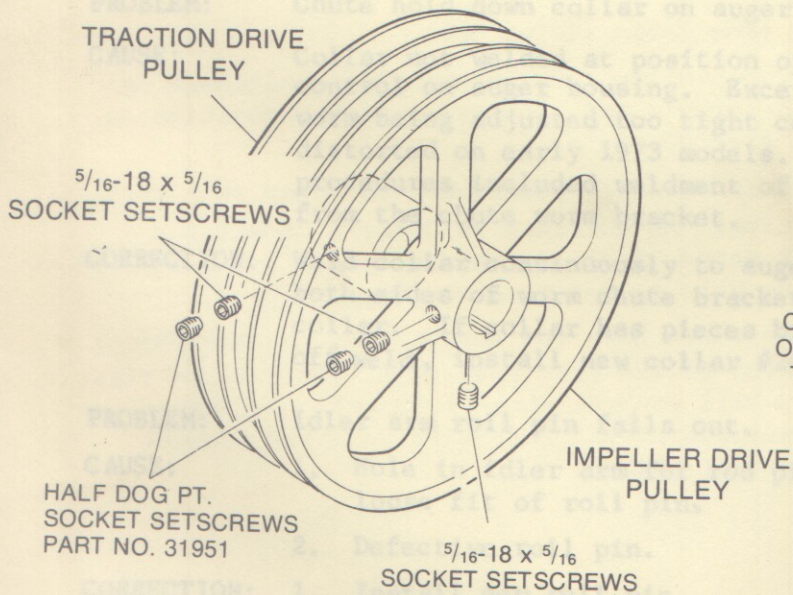

FIG. 3

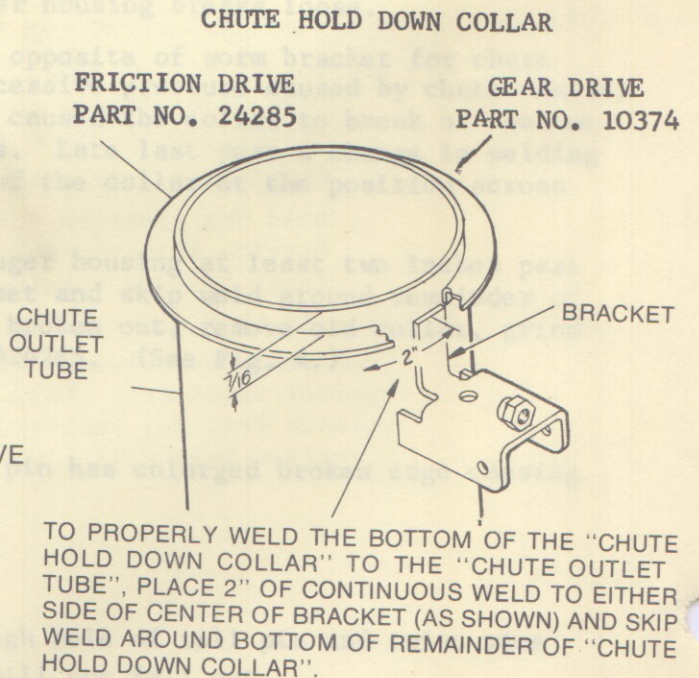

FIG. 4